

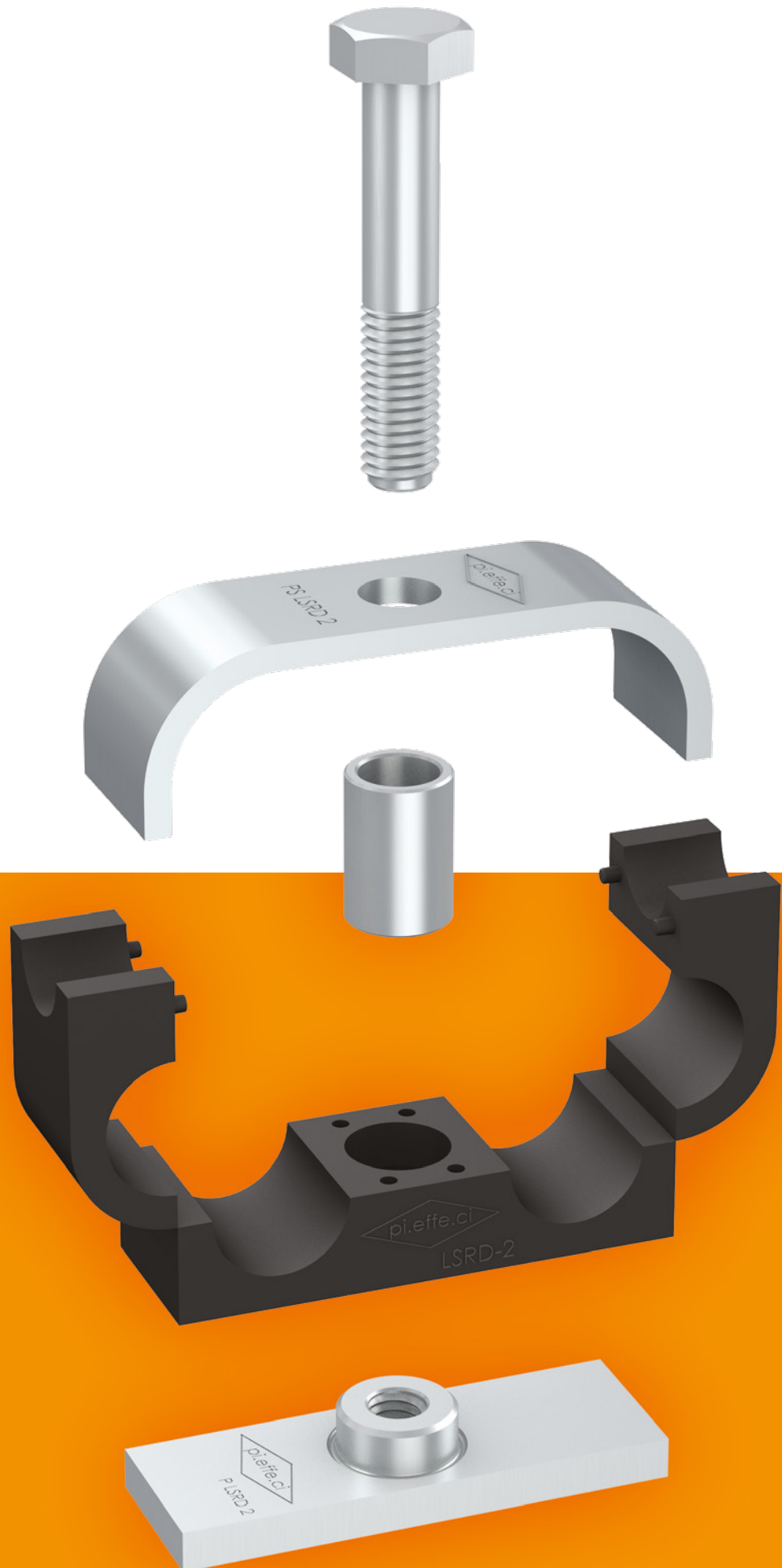

PIPE CLAMPS **LIGHT SERIES**
Order Codes and Dimensions (mm/in)

PIPE CLAMPS
LIGHT SERIES

88





PIPE CLAMPS **LIGHT SERIES**

PIPE CLAMPS
LIGHT SERIES

CLAMP BODY STANDARD MATERIALS



Polypropylene
Colour **Blue**
Code **PP**

**OTHER COLOURS
AVAILABLE ON DEMAND!**



Polyamide
Colour **Black**
Code **PA6**



Self-extinguishing Polypropylene
Colour **White**
Code **AU**



Rubber Elastomer
Colour **Black**
Code **GM**

DIFFERENT DIAMETERS AND MATERIALS AVAILABLE ON REQUEST.

ON REQUEST, ANY CLAMP BODY CAN BE SUPPLIED
WITH TWO DIFFERENT DIAMETERS.

Clamp body internal surface:
Smooth (A, B, C, LSRA, LSRD)
Profiled (LS, LSCF)

For Material Characteristics, see Technical Appendix (page 147).

COMPONENTS AND ACCESSORIES STANDARD MATERIALS

Carbon Steel S 235 JR with finishing surface in white zinc-coated
Fe Zn c8 II.

Untreated are available on request.

DIFFERENT MATERIALS AVAILABLE ON REQUEST.

The **BB** track is treated with zinc-plating SENDZIMIR.

Metric thread: code **M**
UNC thread: code **UNC**.

For Material Characteristics, see Technical Appendix (page 147).





A CLAMP BODY

(IDENTICAL DIAMETERS)

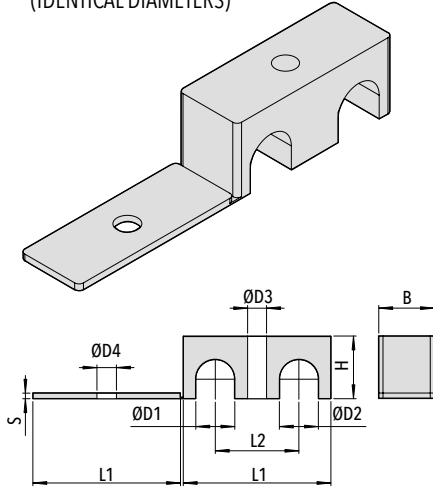

Code A (PP - PA6 - AU)

ORDER EXAMPLE

A - 6 - 6 - PP

Code	O.D. ØD1 / ØD2		L1	L2	B	H	S	ØD3	ØD4
	mm	nominal bore pipe in							
4									
6			31 (1.22")	18 (.71")	12,8 (.50")	10,5 (.41")	2 (.08")	6,8 (.27")	7 (.28")
8									
9,5		3/8"							
10		1/8"	39 (1.54")	22 (.87")	16 (.63")	15 (.59")	2 (.08")	6,8 (.27")	7 (.28")
12									
12,7		1/2"							
13,5		1/4"							
14									
15			53 (2.09")	30 (1.18")	20 (.79")	22,5 (.89")	2 (.08")	6,8 (.27")	7 (.28")
16		5/8"							
17,2		3/8"							
18									
19		3/4"							
20									
21,3		1/2"	70 (2.76")	38 (1.50")	20 (.79")	30 (1.18")	2 (.08")	6,8 (.27")	7 (.28")
22		7/8"							
25,4		1"							

90

B CLAMP BODY

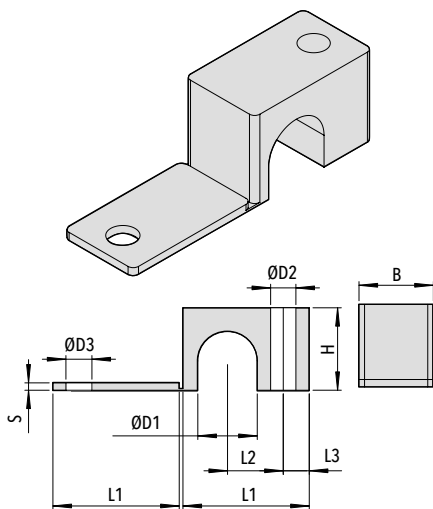

Code B (PP - PA6 - AU)

ORDER EXAMPLE

B - 10 - PP

Code	Outside Diameter ØD1		L1	L2	L3	B	H	S	ØD2	ØD3
	mm	nominal bore pipe in								
4										
6			22 (.87")	9 (.35")	6,5 (.26")	12,8 (.50")	10,5 (.41")	2 (.08")	6,8 (.27")	7 (.28")
8										
9,5		3/8"								
10		1/8"	27 (1.06")	11 (.43")	7 (.28")	16 (.63")	15 (.59")	2 (.08")	6,8 (.27")	7 (.28")
12										
12,7		1/2"								
13,5		1/4"								
14										
15			34 (1.34")	15 (.59")	7 (.28")	20 (.79")	22,5 (.89")	2 (.08")	6,8 (.27")	7 (.28")
16		5/8"								
17,2		3/8"								
18										
19		3/4"								
20										
21,3		1/2"	42 (1.65")	19 (.75")	7 (.28")	20 (.79")	30 (1.18")	2 (.08")	6,8 (.27")	7 (.28")
22		7/8"								
25,4		1"								



C CLAMP BODY

(DIFFERENT DIAMETERS)

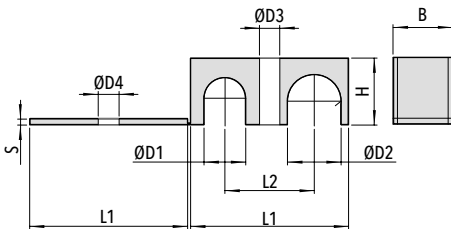
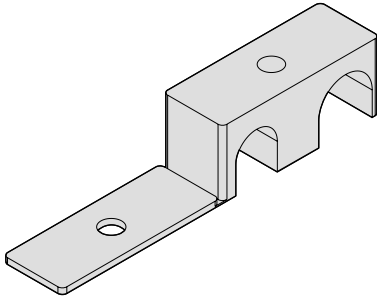

Code C (PP - PA6 - AU)

Code	O.D. ØD1 / ØD2		L1	L2	B	H	S	ØD3	ØD4
	mm	nominal bore pipe in							
4-6									
4-8			31 (1.22")	18 (.71")	12,8 (.47")	10,5 (.41")	2 (.08")	6,8 (.27")	7 (.28")
6-8									
10-9,5	1/8"	3/8"							
12-9,5		3/8"	39 (1.54")	22 (.87")	16 (.63")	15 (.59")	2 (.08")	6,8 (.27")	7 (.28")
10-12	1/8"								
13,5-12,7	1/4"	1/2"							
14-12,7		1/2"							
15-12,7		1/2"							
16-12,7		1/2"							
17,2-12,7	3/8"	1/2"							
18-12,7		1/2"							
13,5-14	1/4"								
13,5-15	1/4"								
13,5-16	1/4"	5/8"							
13,5-17,2	1/4"-3/8"								
13,5-18	1/4"		53 (2.09")	30 (1.18")	20 (.79")	22,5 (.89")	2 (.08")	6,8 (.27")	7 (.28")
14-15									
14-16		5/8"							
17,2-14	3/8"								
14-18									
15-16		5/8"							
17,2-15	3/8"								
15-18									
17,2-16	3/8"	5/8"							
16-18									
17,2-18	3/8"								
20-19		3/4"							
21,3-19	1/2"	3/4"							
22-19		7/8"-3/4"							
25,4-19		1"-3/4"							
21,3-20	1/2"		70 (2.76")	38 (1.5")	20 (.79")	30 (1.18")	2 (.08")	6,8 (.27")	7 (.28")
22-20		7/8"							
21,3-22	1/2"	7/8"							
21,3-25,4	1/2"	1"							
22-25,4		7/8"-1							

C

PIPE CLAMPS
LIGHT SERIES

ORDER EXAMPLE

C - 15-12,7 - PP



LS CLAMP BODY

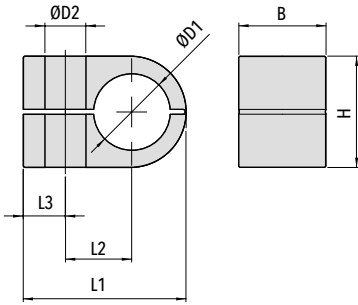
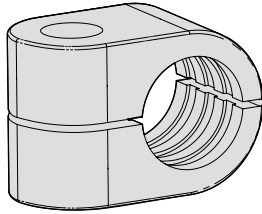

Code	Outside Diameter ØD1		L1	L2	L3	B	H	ØD2
	mm	nominal bore pipe in						
LS1	6							
	6,4	1/4"	22 (.87")	9 (.35")	7 (.28")	14,5 (.57")	13,5 (.53")	6,8 (.27")
	8	5/16"						
LS2	8	5/16"						
	9,5	3/8"						
	10	1/8"	27 (1.06")	11 (.43")	7 (.28")	14,5 (.57")	18,5 (.73")	6,8 (.27")
	12							
	12,7	1/2"						
LS3	10	1/8"						
	12							
	12,7	1/2"						
	13,5	1/4"	33 (1.30")	15 (.59")	7 (.28")	14,5 (.57")	23,5 (.93")	6,8 (.27")
	14							
	15							
LS4	16	5/8"						
	14							
	15							
	16	5/8"						
	17,2	3/8"						
	18		40 (1.57")	19 (.75")	7 (.28")	14,5 (.57")	30,5 (1.20")	6,8 (.27")
	19	3/4"						
20								
21,3	1/2"							
22	7/8"							

ORDER EXAMPLE

LS2 - 10 - PP



LSCF CLAMP BODY

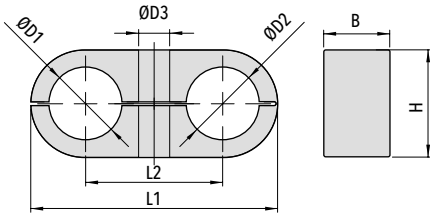
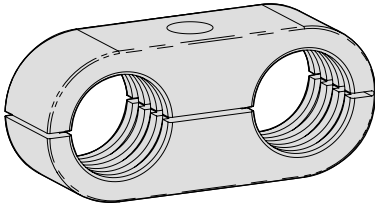

Code LSCF (PP - PA6 - AU)

ORDER EXAMPLE

LSCF3 - 15 - PP

Code	O.D. ØD1 / ØD2		L1	L2	B	H	ØD3
	mm	nominal bore pipe in					
LSCF1	6						
	6,4	1/4"	32 (1.26")	18 (.70")	14,5 (.57")	13,5 (.53")	6,8 (.27")
	8	5/16"					
LSCF2	8	5/16"					
	9,5	3/8"					
	10	1/8"	41 (1.61")	22 (.86")	14,5 (.57")	18,5 (.73")	6,8 (.27")
	12						
	12,7	1/2"					
LSCF3	10	1/8"					
	12						
	12,7	1/2"					
	13,5	1/4"	54 (2.13")	30 (1.18")	14,5 (.57")	23,5 (.93")	6,8 (.27")
	14						
	15						
	16	5/8"					
LSCF4	14						
	15						
	16	5/8"					
	17,2	3/8"					
	18		70 (2.76")	38 (1.50")	14,5 (.57")	30,5 (1.20")	6,8 (.27")
	19	3/4"					
	20						
21,3	1/2"						
22	7/8"						

PIPE CLAMPS
LIGHT SERIES

PS LSCF UPPER PLATE

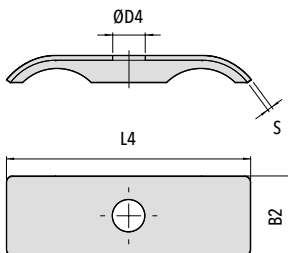
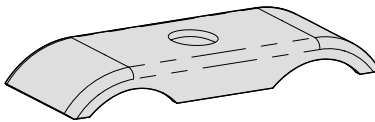

Code PS LSCF (Carbon Steel S 235 JR)

Code	L4	B2	ØD4	S
PS LSCF1	29,5 (1.16")	15,5 (.61")	6,8 (.27")	1 (.04")
PS LSCF2	40 (1.57")	15,5 (.61")	6,8 (.27")	1 (.04")
PS LSCF3	51 (2.01")	16 (.63")	6,8 (.27")	1 (.04")
PS LSCF4	63,5 (2.50")	16 (.63")	6,8 (.27")	1 (.04")



LSRA CLAMP BODY

PIPE CLAMPS
LIGHT SERIES

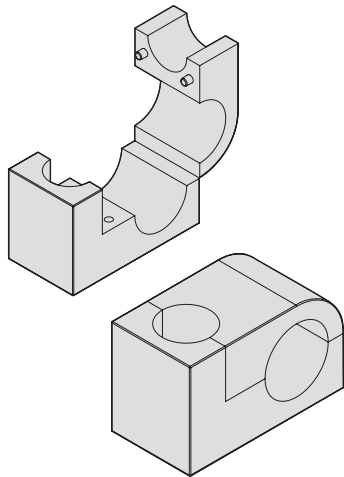

94

Code LSRA (Material GM)

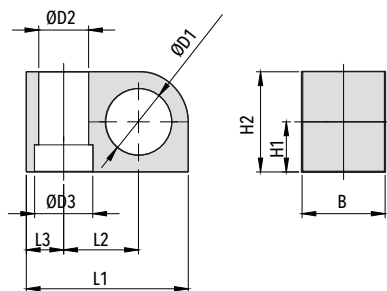

Code	Outside Diameter ØD1		ØD2	ØD3	L1	L2	L3	H1	H2	B
	mm	nominal bore pipe in								
	6									
	6,4	1/4"								
	8	5/16"								
LSRA1	9,5	3/8"	12	14	34	15	9	10	20	20
	10	1/8"	(.47")	(.55")	(1.34")	(.59")	(.35")	(.39")	(.79")	(.79")
	11									
	12									
	12,7	1/2"								
	4									
	6									
	6,4	1/4"								
	8	5/16"								
	9,5	3/8"								
	10	1/8"								
	11									
	12									
LSRA2	12,7	1/2"	12	14	39	18	9	12	24	20
			(.47")	(.55")	(1.54")	(.71")	(.35")	(.47")	(.94")	(.79")
	13,5	1/4"								
	14									
	15									
	16	5/8"								
	17,2	3/8"								
	18									
	19	3/4"								
	20									
	21,3	1/2"								
	22	7/8"								
	23									
LSRA3	25		12	14	57,5	23,5	15	20	40	30
	25,4	1"	(.47")	(.55")	(2.26")	(.93")	(.59")	(.79")	(1.57")	(1.18")
	28									
	30									
	32	1.1/4"								

ORDER EXAMPLE

LSRA2 - 12 - GM



PLSRA WELD PLATE

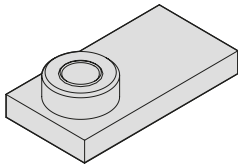
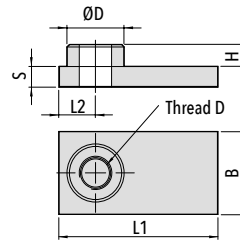

Code	Thread D	L1	L2	B	H	S	ØD
PLSRA1	M8 (5/16-18 UNC)	34 (1.34")	9 (.35")	20 (.79")	6 (.23")	5 (.20")	14 (.55")
PLSRA2	M8 (5/16-18 UNC)	39 (1.54")	9 (.35")	20 (.79")	6 (.23")	5 (.20")	14 (.55")
PLSRA3	M8 (5/16-18 UNC)	57,5 (2.26")	15 (.59")	30 (1.18")	6 (.23")	5 (.20")	14 (.55")

Code PLSRA (Carbon Steel S 235 JR)

PSLSRA UPPER PLATE

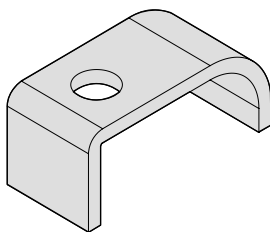
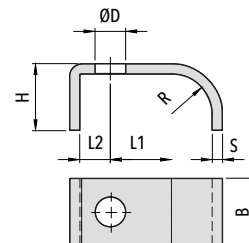

Code	L1	L2	B	H	R	S	ØD
PSLSRA1	15 (.59")	9 (.35")	20 (.79")	16 (.63")	10 (.39")	3 (.12")	9 (.35")
PSLSRA2	18 (.71")	9 (.35")	20 (.79")	20 (.79")	12 (.47")	3 (.12")	9 (.35")
PSLSRA3	23,5 (.93")	15 (.59")	30 (1.18")	28 (1.10")	19,5 (.77")	3 (.12")	9 (.35")

Code PSLSRA (Carbon Steel S 235 JR)



LSRD CLAMP BODY

PIPE CLAMPS
LIGHT SERIES

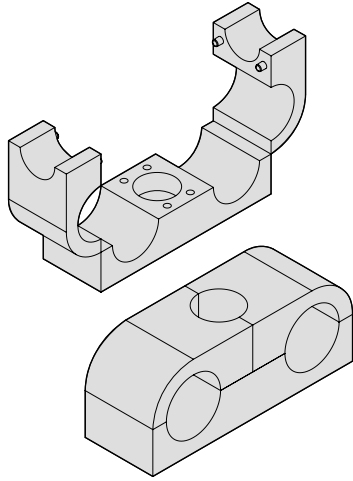

96

Code LSRD (Material GM)

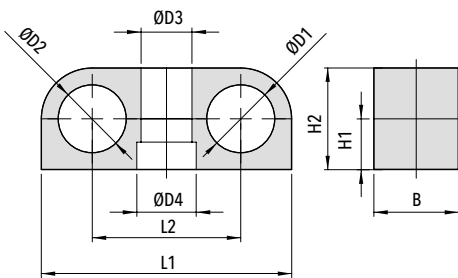

Code	O.D. ØD1 / ØD2		ØD3	ØD4	L1	L2	H1	H2	B
	mm	nominal bore pipe in							
	4								
	6								
	6,4	1/4"							
	8	5/16"							
LSRD1	9,5	3/8"	12 (.47")	14 (.55")	50 (1.97")	30 (1.18")	10 (.39")	20 (.79")	20 (.79")
	10	1/8"							
	11								
	12								
	12,7	1/2"							
	4								
	6								
	6,4	1/4"							
	8	5/16"							
	9,5	3/8"							
	10	1/8"							
	11								
	12								
LSRD2	12,7	1/2"	12 (.47")	14 (.55")	59 (2.32")	35 (1.38")	12 (.47")	24 (.94")	20 (.79")
	13,5	1/4"							
	14	1/2"							
	15								
	16	5/8"							
	17,2	3/8"							
	18								
	19	3/4"							
	20								
	21,3	1/2"							
	22	7/8"							
	23								
LSRD3	25		12 (.47")	14 (.55")	86 (3.39")	47 (1.85")	20 (.79")	40 (1.57")	30 (1.18")
	25,4	1"							
	28								
	30								
	32	1.1/4"							

ORDER EXAMPLE

LSRD3 - 25 - GM



PLSRD WELD PLATE

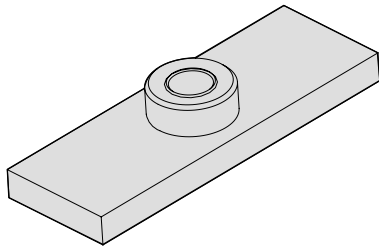
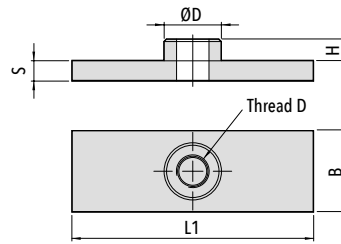

Code	Thread D	L1	B	H	S	ØD
PLSRD1	M8 (5/16-18 UNC)	50 (1.97")	20 (.79")	6 (.23")	5 (.20")	14 (.55")
PLSRD2	M8 (5/16-18 UNC)	59 (2.32")	20 (.79")	6 (.23")	5 (.20")	14 (.55")
PLSRD3	M8 (5/16-18 UNC)	86 (3.39")	30 (1.18")	6 (.23")	5 (.20")	14 (.55")

Code PLSRD (Carbon Steel S 235 JR)

PSLSRD UPPER PLATE

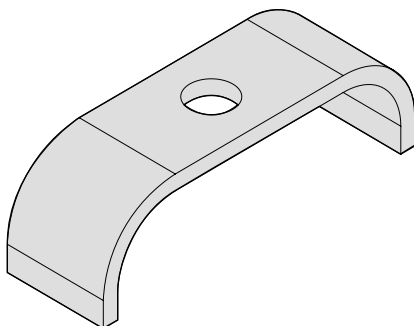
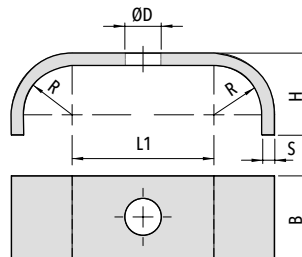

Code	L1	B	H	R	S	ØD
PSLSRD1	30 (1.18")	20 (.79")	16 (.63")	10 (.39")	3 (.12")	9 (.35")
PSLSRD2	35 (1.38")	20 (.79")	20 (.79")	12 (.47")	3 (.12")	9 (.35")
PSLSRD3	47 (1.85")	30 (1.18")	28 (1.10")	19,5 (.77")	3 (.12")	9 (.35")

Code PSLSRD (Carbon Steel S 235 JR)



D LSR BUSHING

DC LSR
FOR USE WITH
MOUNTING RAIL **BB**

DM LSR
FOR USE WITH
WELD PLATE **PLSRA** OR **PLSRD**

DL LSR
FOR USE
WITHOUT WELD PLATE

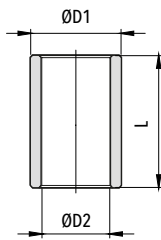

Code	ØD1	ØD2	L
------	-----	-----	---

Code	ØD1	ØD2	L
------	-----	-----	---

Code	ØD1	ØD2	L
------	-----	-----	---

DC LSR1 12 9 12,8
(.47") (.35") (.50")

DM LSR1 12 9 13,5
(.47") (.35") (.53")

DL LSR1 12 9 18,8
(.47") (.35") (.74")

DC LSR2 12 9 16,8
(.47") (.35") (.66")

DM LSR2 12 9 17,5
(.47") (.35") (.69")

DL LSR2 12 9 22,7
(.47") (.35") (.89")

DC LSR3 12 9 32,8
(.47") (.35") (1.29")

DM LSR3 12 9 33,5
(.47") (.35") (1.32")

DL LSR3 12 9 38,8
(.47") (.35") (1.53")

See Mounting Examples
nn. 7 and 9

See Mounting Examples
nn. 6 and 10

See Mounting Examples
nn. 5 and 8

Code **D LSR** (Carbon Steel S 235 JR)

TE HEXAGON HEAD BOLT

ISO 4014 / 4017

TE C-M
FOR USE WITH MOUNTING RAIL **BB**,
WELD PLATE **PLSRA** OR **PLSRD**

TE L
FOR USE
WITHOUT WELD PLATE

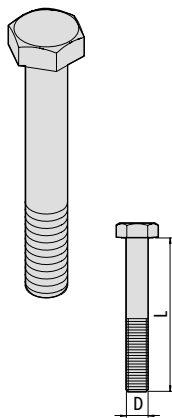

Code	Thread (D x L)
------	----------------

Code	Thread (D x L)
------	----------------

M8x25
(5/16-18 UNCx1")

M8x30
(5/16-18 UNCx1-1/4")

TE C-M

M8x30
(5/16-18 UNCx1-1/8")

TE L

M8x35
(5/16-18 UNCx1-3/8")

M8x45
(5/16-18 UNCx1-3/4")

M8x50
(5/16-18 UNCx2")

Code **TE** (Steel 8.8)



BB MOUNTING RAIL

AVAILABLE HEIGHTS 11 / 14 / 30 mm
AVAILABLE LENGTH 2 m

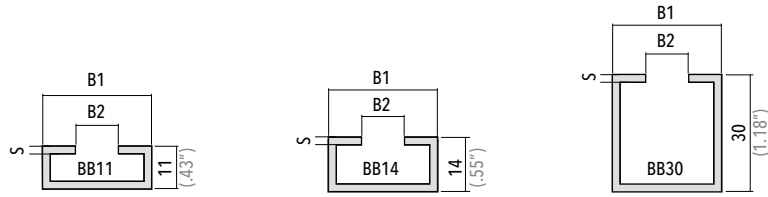
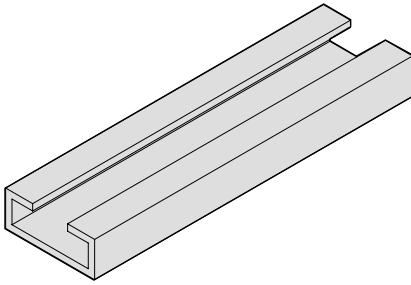

Code	B1	B2	S
BB XBB	28 (1.10")	11 (.43")	2 (.08")

Code **BB** (Steel DX51D)
Code **XBB** (Stainless Steel AISI 316L)

PIPE CLAMPS
LIGHT SERIES

DF+AG RAIL NUT WITH RUBBER RING

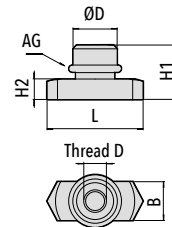

99

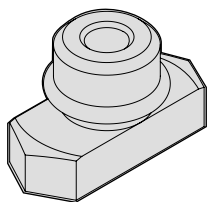

Code	Thread D	L	B	H1	H2	ØD	AG
DF XDF	M8 (5/16-18 UNC)	25,5 (1.00")	10,4 (.41")	13,5 (.53")	5 (.20")	13,8 (.54")	10x2,2 (.39"x.08")

Code **DF** (Steel C20)
Code **XDF** (Stainless Steel AISI 316L)

MOUNTING EXAMPLE 01

Mounting Example of clamp Type B 10 PP in Polypropylene for pipe with outside diameter of 10 mm.

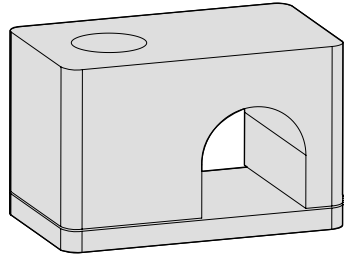

MOUNTING EXAMPLE 02

Mounting Example of clamp Type A 10-10 PP in Polypropylene for pipe with outside diameter of 10 mm.

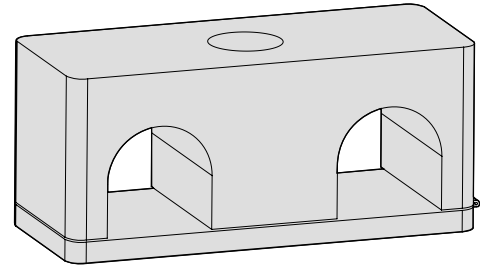

100

MOUNTING EXAMPLE 03

Mounting Example of clamp LS1 8 PP in Polypropylene for pipe with outside diameter of 8 mm.

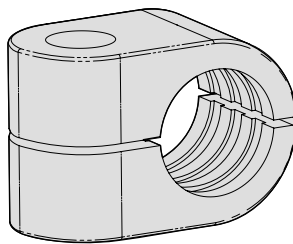

MOUNTING EXAMPLE 04

Mounting Example of clamp LSCF1 08-08 PP in Polypropylene for pipe with outside diameter of 8 mm with upper plate PS LSCF1.

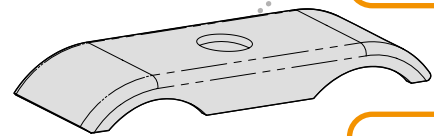

N.1 PS LSCF1
Upper plate
in Stainless Steel S 235 JR
Surface finishing
white zinc-plating

N.1 LSCF1 08-08PP
Clamp body
in Polypropylene

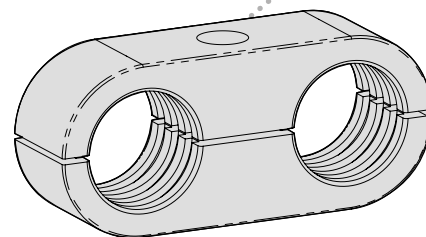



MOUNTING EXAMPLE 05

Mounting Example clamp LSRA with weld plate.

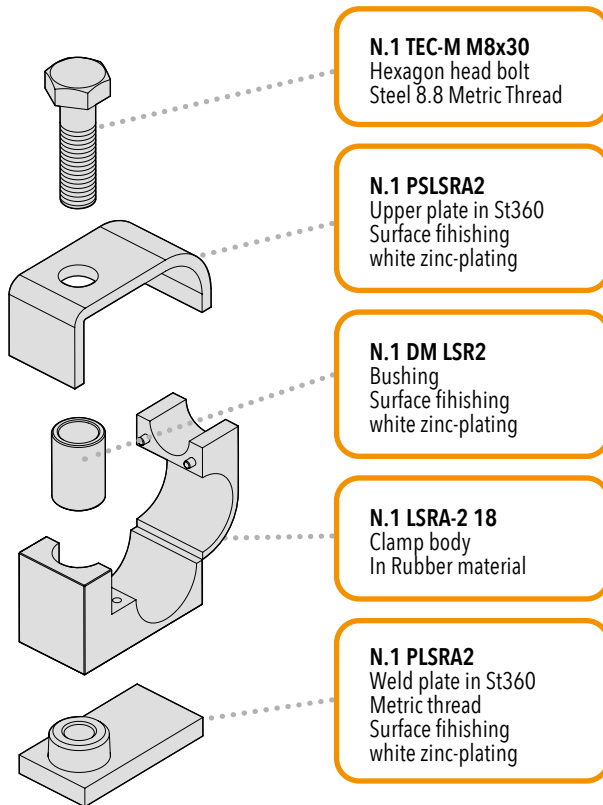

MOUNTING EXAMPLE 06

Mounting Example clamp LSRA for panel mounting without weld plate or hexagon rail nut.

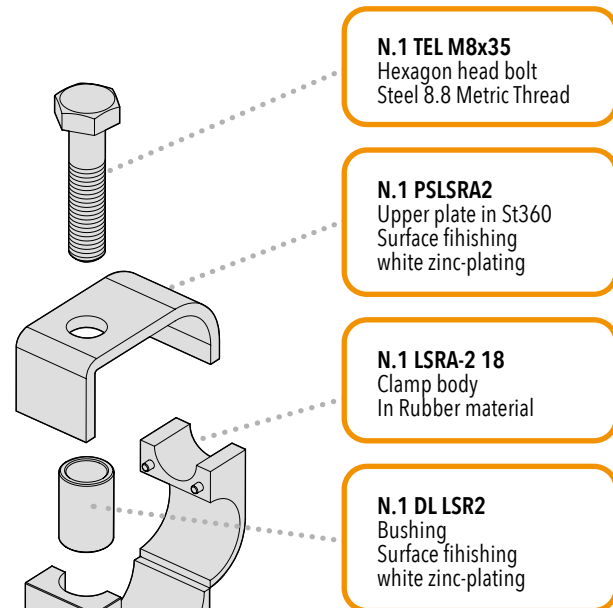

MOUNTING EXAMPLE 07

Mounting Example clamp LSRA with hexagon rail nut.

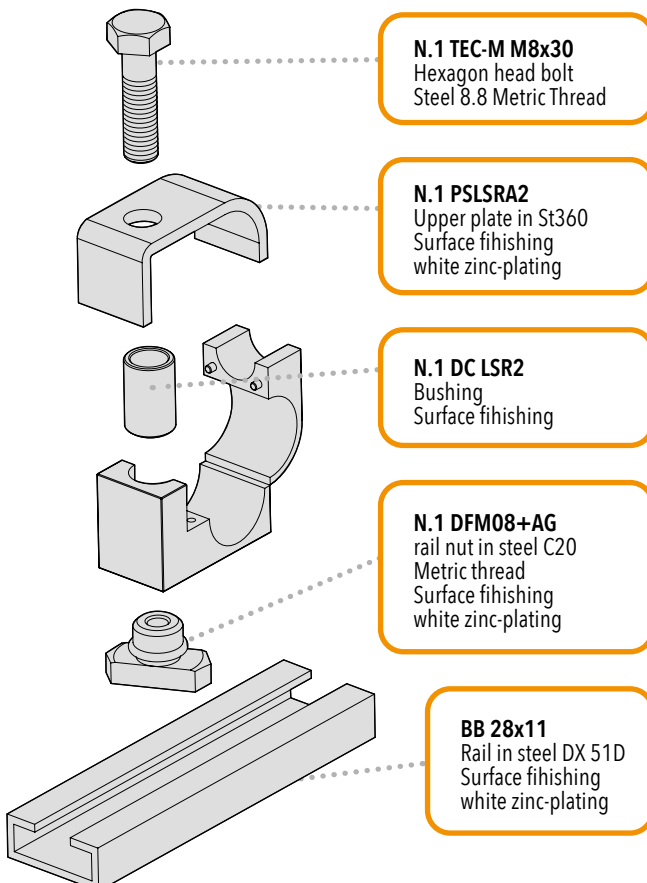

MOUNTING EXAMPLE 08

Mounting Example clamp LSRD with weld plate.

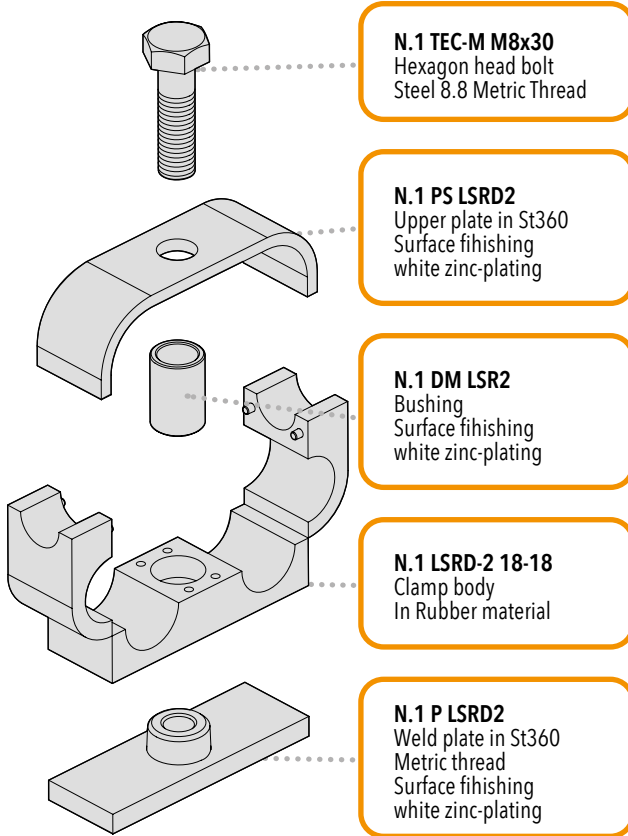
MOUNTING EXAMPLE 09

Mounting Example clamp LSRD with hexagon rail nut.

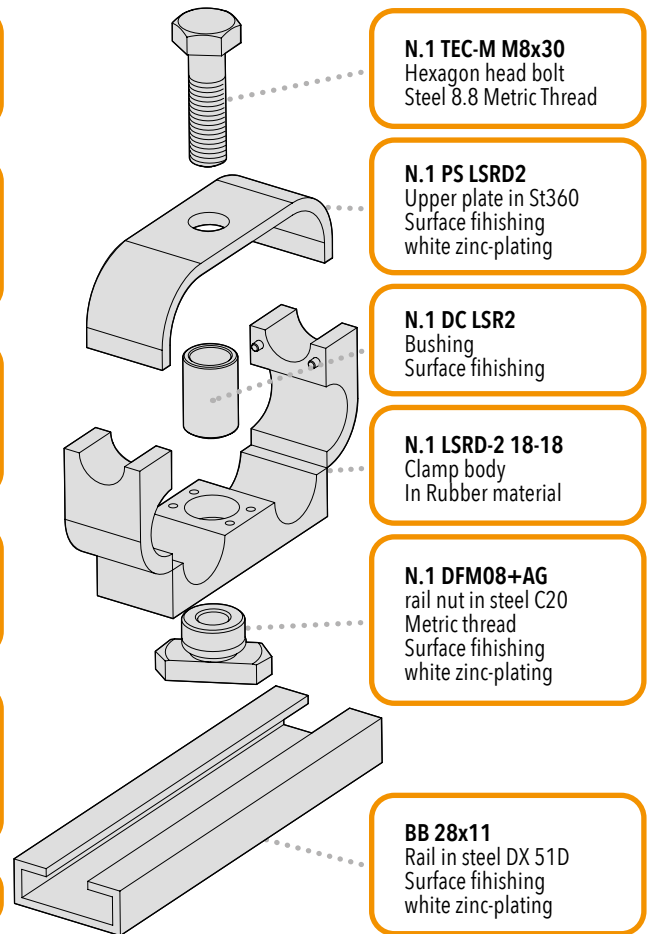
MOUNTING EXAMPLE 10

Mounting Example clamp LSRD for panel mounting without weld plate or hexagon rail nut.

